

See discussions, stats, and author profiles for this publication at: <https://www.researchgate.net/publication/268401483>

High efficient cyclone systems with electrostatic recirculation for particulate matter (PM) emission control

Article

CITATIONS

0

READS

109

2 authors:



[Julio Paiva](#)

Advanced Cyclone Systems, SA

6 PUBLICATIONS 23 CITATIONS

[SEE PROFILE](#)



[Romualdo L. Salcedo](#)

University of Porto

54 PUBLICATIONS 897 CITATIONS

[SEE PROFILE](#)

High efficient cyclone systems with electrostatic recirculation for particulate matter (PM) emission control

Júlio Paiva^{1*}, Romualdo Salcedo^{1,2}

¹ Advanced Cyclone Systems, SA.,
Centro de Empresas NET - Edifício PROMONET
Rua de Salazares, 842, 4149-002 Porto, Portugal

² LEPAE, Departamento de Engenharia Química
Faculdade de Engenharia da Universidade do Porto
Rua Dr. Roberto Frias, s/n 4200-465 Porto, Portugal

Abstract

The development of new optimized dedusting systems has particular and increasing relevance for atmospheric particulate emission control. Indeed, traditional “particulate traps” present several disadvantages that foster the search for alternative solutions.

Industrial cyclones are, for their robust construction, absence of moving parts and general application, an appropriate technology for emission control when dealing with temperatures as high as those in biomass boilers. Nevertheless, cyclones’ relatively low efficiency, particularly for small ($< 10 \mu m$) and low density particles, leads many users to complement them with Bag Filters (BF) or Electrostatic Precipitators (ESP). Usually, BFs are financially bearable and very efficient ($>99.9\%$), but are maintenance demanding due to frequent change of filter elements. On the other hand, ESPs are robust equipments and are very effective (in a given range of dust resistivity) but their high investment cost is frequently out of reach of small and medium size companies.

Electrostatic ReCyclone[®] Systems appear as an effective alternative to the traditional solutions, since they combine several key advantages of the referred systems, mainly a numerically optimized gas-cyclone geometry (referred as Hurricane[®]) and electrostatic precipitation, allowing biomass boilers to comply with strict legal emissions limits. ReCyclone[®] systems consist of an optimized reverse-flow cyclone (which can have, by itself, about half of the emissions of other high-efficiency cyclones), combined with partial recirculation of un-captured particles via a straight-through cyclone concentrator (recirculator). Particle separation in the recirculator is achieved via the application of a DC electric field combined with centrifugal forces. Global efficiency is further enhanced through a very relevant phenomenon inside cyclones, which is agglomeration/clustering of very fine particles with larger particles in the turbulent flow field inside the gas cyclone.

In order to build a custom made solution for each situation, numerical simulations are made using a model, referred as PACyc, which is based on previously published models to predict collection efficiency either for isolated cyclones, or for cyclones with recirculation. This model considers not only the flow conditions inside the system, but also the particle agglomeration phenomenon. Considering that cyclone efficiency is sensitive to particle size, if the particles “seem” larger to the cyclone, their calculated efficiency will significantly increase above theoretical predictions.

These systems have been shown, for industrial and pilot scales, to have very high efficiencies when dealing with the emissions of biomass boilers, allowing these to comply with strict emissions policies, and the PACyc model has been proven as a reliable tool to predict the behavior of these kind of systems, for several different configurations, several kinds of dusts and operation conditions.

Keywords: Emission control, Cyclone, Optimization, Modelling, Hurricane[®], ReCyclone[®]

*Corresponding author. E-mail: julio.paiva@acsystems.pt, Phone +351-22-5322097, Fax +351-22-5322096

1 Introduction

Cyclones are gas-solid separation devices used in a wide variety of industries, mainly for the recovery of raw or process materials, as collectors for compliance with particulate emission limits, and as primary collectors to decrease the burden on more expensive secondary collectors. Cyclones are essentially attractive for operation at high temperatures and/or pressure, and the development of highly efficient cyclones, especially for fine particles below $2\text{-}3\mu\text{m}$ in diameter, could have a significant impact in the chemical processing industries.

Upon obtaining a numerically optimized cyclone geometry [1–4], in order to increase even more the system performance, partial recirculation of gases to the cyclone has been adopted [5; 6].

Taking into account the three major options available to build such a system, Wysk et al. [7] have built a straight-through gas cyclone placed upstream of the reverse gas cyclone.

This information was taken into account and Salcedo et al. [5] have shown that by placing the reverse-flow cyclone (collector) upstream from the concentrator, higher efficiencies could be obtained, and have shown that these kind of systems have very high collection efficiencies at laboratory, pilot and industrial scales. These authors have also proposed a model to predict the overall collection efficiency of this system, derived from the Mothes and Löffler's model [8] to predict isolated gas cyclone collection efficiency.

Finally, the inclusion of an electrostatic field in the recirculation system will increase the amount of recirculated particles and consequently the global efficiency. Combining all these steps, the Recyclone[®] EH was developed which as been proven as a good alternative to filters and electrostatic precipitators, obtaining, at moderate loads, very high collection efficiency for submicrometric particles.

Previous work [1; 4–6; 9–13] has shown at laboratory, pilot and industrial-scales that these systems can have much higher collection for fine particles (below about $3\mu\text{m}$) than predicted by classical models, viz. grade-efficiency curves show a minimum in collection at an intermediate particle size (ranging from about 0.8 to $2\mu\text{m}$). In spite of these hook-like curves not always occurring [5; 12], this abnormal behavior for fine particles is attributed to agglomeration within the cyclone turbulent flow field, as initially postulated by Mothes and Löffler [14], much as it happens in recirculating fluidized beds [15; 16].

This phenomenon inside the isolated gas cyclone has been studied by Paiva et al. [17], culminating in the PACyc model (**P**article **A**gglomeration in **C**yclones). This model considers that upon collision/agglomeration of fine particles by larger ones, the smaller particles will be captured as much larger particles, viz. with much higher collection efficiency than that predicted by any of the currently available models.

This agglomeration effect is even more noticeable if the cyclone is highly efficient above about $2\text{-}3\mu\text{m}$, i.e., above 90-95% collection, as it indeed happens with numerically optimized cyclones [1; 3; 4], and especially with recirculation systems (with or without an electric field) [5; 6].

2 Modeling

Figure 1 presents the system studied in this work, composed by a numerically optimized reverse-flow gas-cyclone and a straight-through cyclone (referred here as concentrator).

To use the PACyc model to predict the collection efficiency of the system with partial recirculation, it is not only necessary to know the geometrical parameters of the system but also the operating conditions and several simulation parameters.

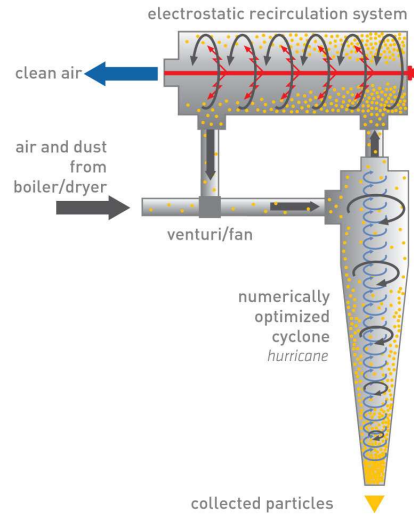

Figure 1: System studied in this work

Knowing these parameters, a baseline efficiency curve is obtained, upon which the new composite efficiency curve is built taking into account the agglomeration effect. In terms of its main constituents, the PACyc model adopts the Mothes and Löffler model [8] to predict the reverse-flow gas cyclone, and the Salcedo et al. [5] model to estimate the collection efficiency of the entire recirculation system. To define the impact of the electrostatic field in the system, a combination of models proposed by several authors [18–20] is used.

In order to build the composite efficiency curve, it is necessary to define the turbulent dispersion coefficient. Due to the different geometry of cyclones, there is some uncertainty in the values to use, but either Salcedo and Coelho [1] or Lorenz [21] derived correlations show a good fit to the experimental results, so they were used in the present work.

For the Salcedo and Coelho [1] correlation an analogy is made between turbulent dispersion of the solid phase in cyclone flow and turbulent dispersion processes in flows through packed beds, while for Lorenz [21] the correlation was obtained by an empirical fitting. The empirical expressions used to calculate the turbulent dispersion coefficient in each zone in the system are shown in equations 1 and 2.

$$Pe_p = 0.0342 (Re_p)^{1.263} \quad (1)$$

$$D_r = 0.006 \left(1 + \arctan \left(\frac{Re_{tr}}{136864} \right) \right) \quad (2)$$

The radial Peclet number ($Pe_p = \frac{u_r d_p}{D_r}$) includes the value of the radial particle turbulent dispersion (D_r) and $Re_p = \frac{\rho d_p u_r}{\mu}$ is the radial particle Reynolds number. For the Lorenz correlation, the Reynolds number is calculated using the tangential velocity of the gas at the vortex finder exit.

2.1 Reverse flow cyclones efficiency estimation

There are several models available to predict the collection efficiency in reverse flow gas-cyclones. As referred before, previous work [9; 22; 23] has shown that the Mothes and Löffler model [8] gives, on average, the best agreement with available data. Thus, this model was retained as the model

used to predict grade-efficiency in cyclones, in the absence of particle collision/agglomeration, viz., the baseline curve for isolated cyclones.

The main hypothesis assumed in the Mothes and Löffler model are:

- The cyclone flow-field is divided in 4 parts: the entrance area, the downstream flow region, the re-entrainment region and the region of upstream flow;
- The tangential velocity depends only on the radial coordinate and not on the axial coordinate;
- The particle motion is determined as the sum of a random movement (due to the gas turbulence) and a deterministic movement (due to the flow of particles in the centrifugal field);
- For the removal of particles from the gas, particles entering the upward inner vortex are lost, while particles colliding with the cyclone wall are captured.
- Reentrainment of already deposited particles from the conical part is essentially due to the turbulent back mixing of particles near the cyclone bottom. Reentrainment was however ignored in the present paper.

In order to determine the collection efficiency, a mass balance is established between the region of escaping particles (upstream flow) and the entry area.

2.2 Straight-trough cyclone (concentrator)

In order to predict the behavior of the system with recirculation, the model developed by Salcedo et al. [5] is considered.

The main hypothesis assumed are adapted from the ones in the Mothes and Löffler [8] model, considering also that:

- There is no capture zone in the recirculator and consequently no reentrainment;
- The processed particle size distribution (PSD) is updated in an interactive procedure, until the change in the PSD is less than a specified error; This process is shown in Figure 2;

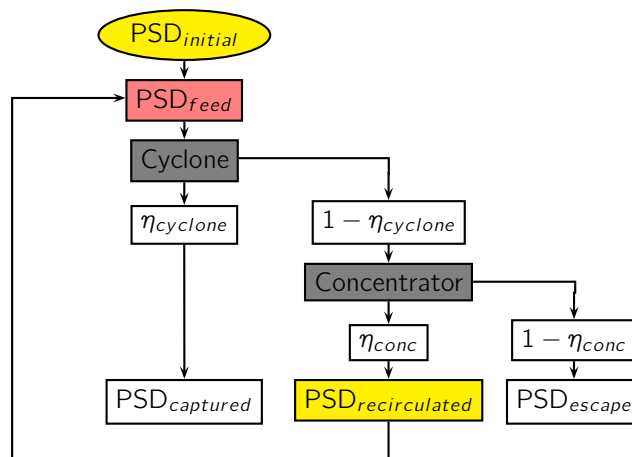

Figure 2: Iterative process concerning the processed particle size distribution

Finally, and in order to determine the collection efficiency, a mass balance is established between the inlet and outlet of the recirculator.

2.3 Particle charging and collection in electric fields

Concerning this subject, several authors proposed different approaches to this matter, but the combination of classical models [18–20] leads to a good enough approximation of the reality occurring in the electrostatic recirculator.

In order to simplify the analysis of this subject, Figure 3 shows the major steps involved in this procedure. As a small explanation, the circles stand for input/output to/from the model, while the boxes stand for mathematical operations.

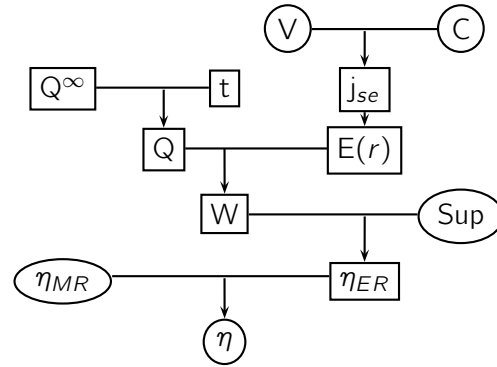

Figure 3: Information flow diagram to illustrate the internal operations of the electrical model

Knowing the applied voltage (V) and recirculator inlet particle concentration (C), using standard expressions proposed in the literature, the current density inside the recirculator (j_{SE}) is obtained, and using this value, the electric field as function of radial position ($E(r)$) can be obtained.

On the other hand, combining geometrical, operation and particle data, the saturation particle charge (Q^∞) is calculated and with the charging time (t), the actual particle charge inside the recirculator can be obtained, using both contributions from electric field and diffusion charging.

Considering the radial variation of the field ($E(r)$), one obtains the terminal electrical velocity (particle electrical migration velocity, W) and defining a separation interface, it is possible to obtain the particle collection efficiency due to the presence of the electric field.

Combining this value with the predicted efficiency of the system without electric field (η_{RM}), the complete system efficiency (η) is then obtained.

2.4 Interparticle Agglomeration Highlights

The agglomeration effect taken into account in PACyc [17] is based on the Sommerfeld model [15; 24] of particle agglomeration in turbulent flows.

The main hypothesis and steps in the PACyc [17] model are:

- Particle agglomeration in turbulent flows (as those occurring in gas cyclone) due to Brownian diffusion can be neglected [17];
- The particles are injected uniformly in the annular surface between the cyclone inner wall and the vortex finder outer wall;
- By estimating the fluid's velocity superimposing random fluctuations on the velocity field as determined by the Mothes and Löffler [8] model, each injected particle trajectory is studied in order to obtain the corresponding position and velocity;
- The variation of the fluid's tangential velocity with the axial coordinate is not considered, as this dependence is very weak [8; 25].

- One-way coupling is assumed, due to the fact that the system is in dilute phase and in those situations, results are very similar to the ones obtained by two-way coupling [26], but can be obtained much faster.

The intrinsic procedures of the PACyc model are shown in Figure 4. The model starts by calculating the fluid velocity in the control volume, and next the trajectories of each individual particle injected in this control volume. Using a probabilistic criteria, the model defines if particles collide and in case of collision, using an energetic criteria, defines if the result of the collision is an agglomeration.

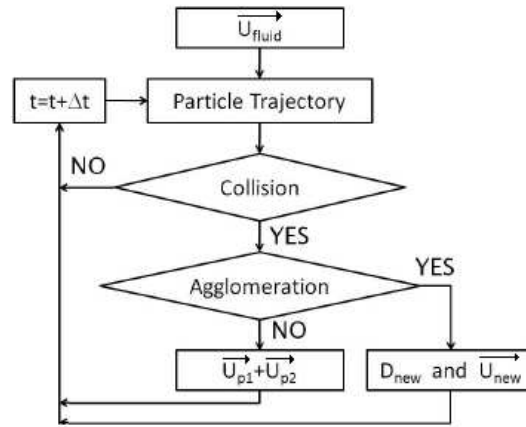

Figure 4: Representation of interparticle agglomeration model

The referred control volume is defined considering only the gray area as relevant for collisions, virtual separation interfaces are included and each particle position has implications on its properties (see Figure 5). It is possible to emphasize that:

- if a particle collides with the wall of the cyclone, it has a null collision probability from that moment on, in the slice where it belongs;
- if a particle crosses to the inner vortex, it escapes from the control volume;
- in a virtual interface, particle removal occurs considering the respective particle efficiency removal in each slice.

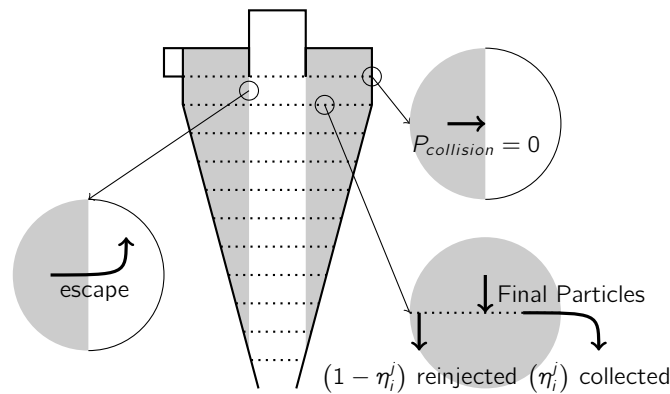

Figure 5: Properties of particles in different zones of the reverse-flow gas cyclone

2.5 Model integration

In order to easily understand integration of the various models, Figure 6 is a simple representative outline of the connection of the major constituents of PACyc applied to systems with recirculation, as presented in this work.

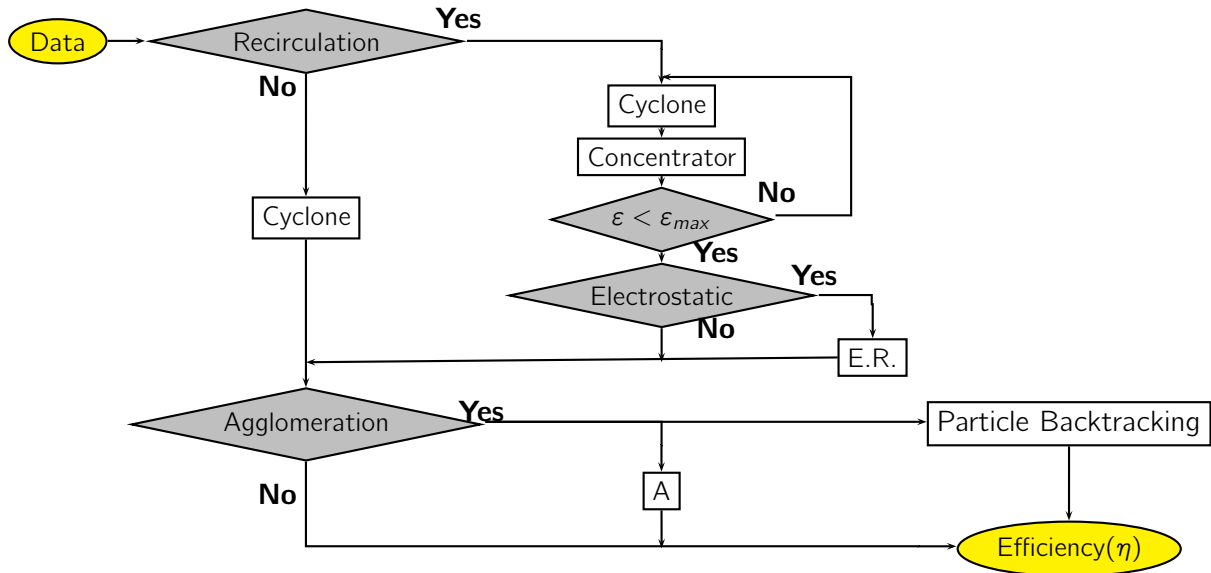

Figure 6: Representation of the different models integration

It is possible to see four different decision zones (marked by diamonds) and each of the global procedures is assembled in the rectangles. With this configuration, it is possible to obtain: cyclone, cyclone with recirculation (with or without electric field) and in all cases, it is possible to consider or neglect particle agglomeration.

However, it is important to refer that PACyc is more than a model integration, since the model can rebuild the grade efficiency curves of the several systems configurations, considering particle agglomeration and respective backtracking to the originally injected particles (historical rebuild). This subject is extensively shown for cases with isolated cyclones in Paiva et. al [17].

3 Experimental results and model prediction

In this section we present experimental results for pilot and industrial case studies, and compare them with PACyc predictions.

3.1 Pilot scale examples

In both pilot scale cases (Figures 7 and 8), a ReCyclone[®] EH with internal diameter of 450 mm with partial recirculation of gases and particles was used and a TOPAS 410G particle feeder was employed to control inlet particle concentration. For the first case the inlet mean velocity was $\approx 18m.s^{-1}$, while for the other case it was $\approx 15m.s^{-1}$. Finally, the experimental grade-efficiency curves were obtained with simultaneous inlet/outlet isokinetic sampling using constant volume samplers (Techora Bravo), in GFA glass fiber filters, and also by online measurements with a GRIMM 1.108 laser spectrometer.

Figure 7 refers to a case of wood waste biomass burned in a gasifier unit. Figure 7a shows off-line measurements using a Coulter LS230 laser sizer and online measurements using the GRIMM monitor ($\rho_p = 2447kg.m^{-3}$, inlet concentration = $2.60 g.m^{-3}$). Figure 7b presents the comparison between the predicted grade-efficiency curve and those obtained experimentally for both measuring methods.

Figure 8 refers to a case of emissions from a vertical lime furnace for cement production. Figure 8a shows off-line measurements using the Coulter laser sizer and online measurements using the

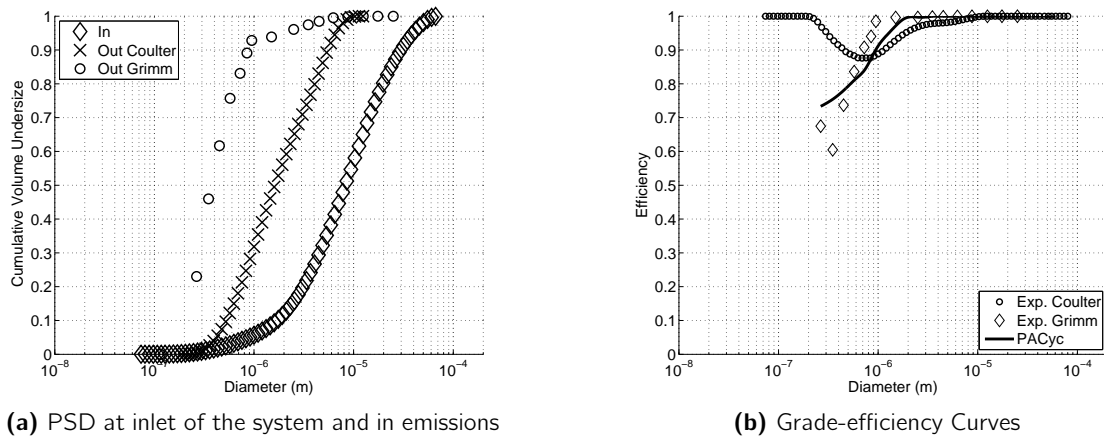

Figure 7: Case 1 - wood waste biomass burned in a gasifier unit

GRIMM monitor ($\rho_p = 2389 \text{ kg.m}^{-3}$, inlet concentration = 0.60 g.m^{-3}), while Figure 8b presents the comparison between the predicted grade-efficiency curve and those obtained experimentally for both measuring methods.

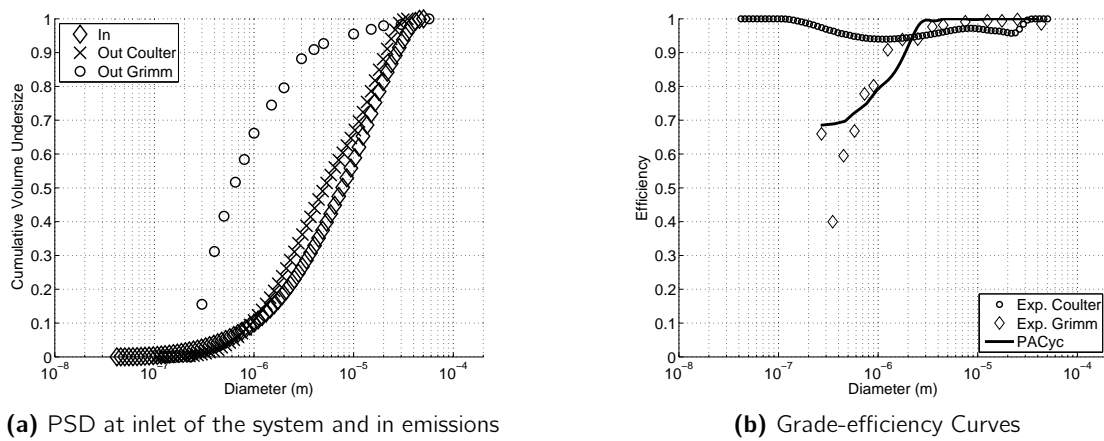

Figure 8: Case 2 - waste of a vertical lime furnace for cement production

Figure 9 shows the experimental overall efficiency as a function of concentration and the respective comparison to PACyc predictions for both cases.

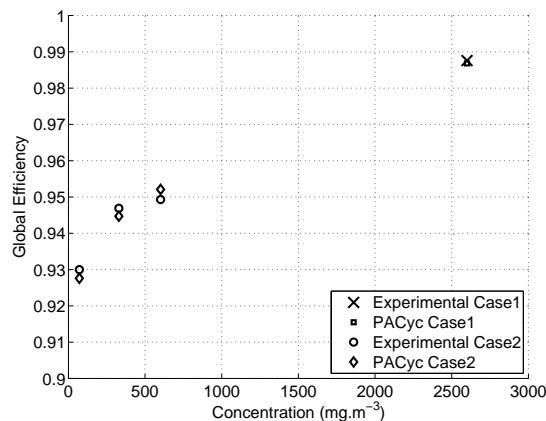

Figure 9: Global efficiency at several concentrations for pilot scale: experimental and PACyc predictions

3.2 Industrial scale examples

Figure 10 refers to a case of fly ash from a cork waste boiler using a ReCyclone[®] MH ($\eta_{ReCyclone^{\text{®}}MH} \approx 93.3\%$). Figure 10a shows off-line measurements using the Coulter laser sizer ($\rho_p = 2785 \text{ kg} \cdot \text{m}^{-3}$, inlet concentration = $0.95 \text{ g} \cdot \text{Nm}^{-3}$ at $300 \text{ }^\circ\text{C}$), while Figure 10b presents the experimental grade-efficiency curve.

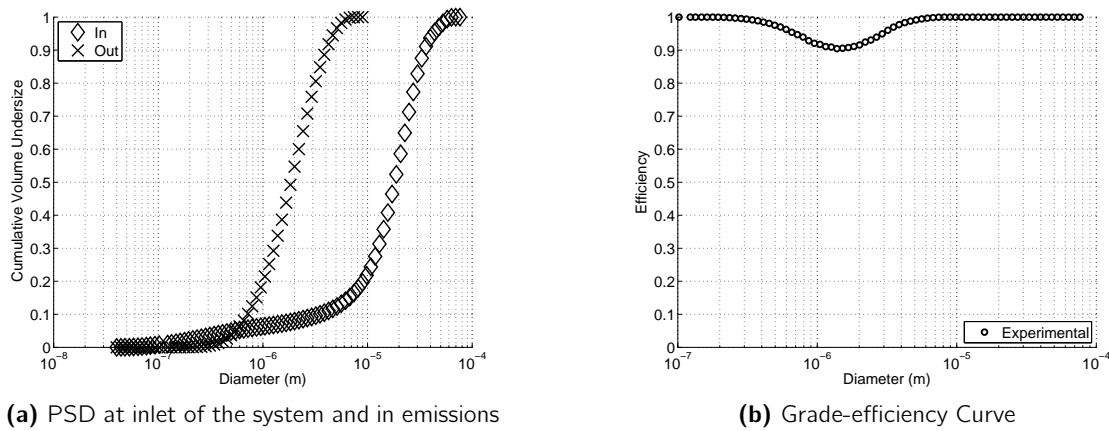

Figure 10: Case 3 - ReCyclone[®] MH industrial application example: biomass heated corkwood boiler

Figure 11 refers to a case of fly ash from a straw fired boiler. Figure 11a shows simultaneously, off-line measurements of captured dust in the installed unit using a Sedigraph ($\rho_p = 2461 \text{ kg} \cdot \text{m}^{-3}$, inlet concentration = $0.50 \text{ g} \cdot \text{Nm}^{-3}$ at 190°C) and PACyc predictions ($\eta_{ReCyclone^{\text{®}}EH} \approx 90.8\%$) where it can be seen that the median mass diameter is very small ($0.84 \mu\text{m}$). Figure 11b presents the characteristic VI curve for the system in operation and its comparison to the predicted values without dust, evidencing clearly the severe corona suppression, due to the very small size of the particles that pass to the recirculator.

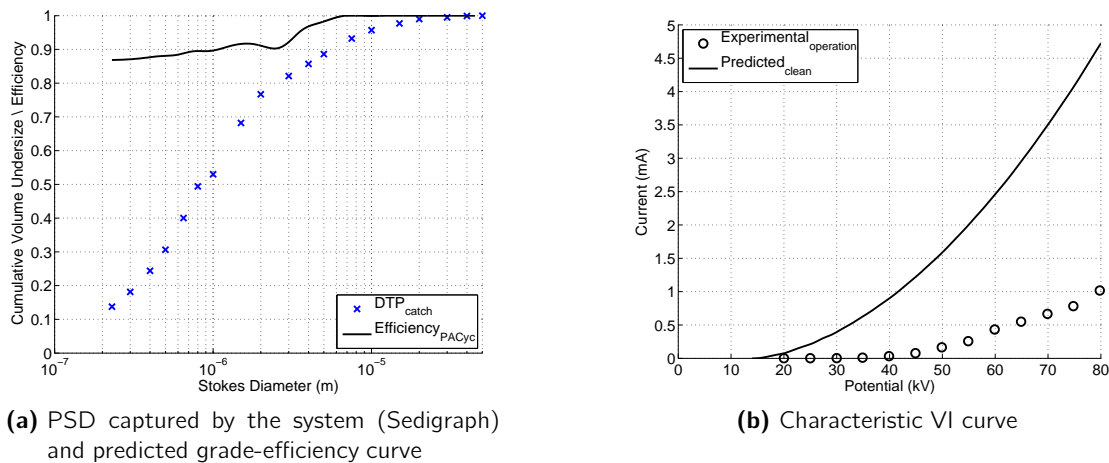

Figure 11: Case 4 - ReCyclone[®] EH industrial application example: straw fired boiler

Considering all the figures shown in this section, it is possible to state that the ReCyclone[®] EH is a well suited system for decreasing particle emission of fine particles. In terms of prediction, the PACyc model seems to be a good tool in order to design optimal systems for each situation, since it predicts reasonably well the experimental data, predicting global efficiencies near to those experimentally obtained.

The ReCyclone[®] EH systems also show an improvement in performance as the concentration increases, being comparable in performance to other commonly used high-end dedusters, such as filters or electrostatic precipitators, at least at moderate concentrations ($< 10 \text{ g} \cdot \text{Nm}^{-3}$).

4 Conclusions

Numerically optimized cyclones and ReCyclone[®] systems were designed by solving appropriate optimization problems. Of these systems, the recirculation system with an electric field in the recirculator has been shown to be highly efficient for the capture of fine particles, such as those usually occurring in biomass boilers. The abnormal high collection of fine submicrometric particles often observed with these systems is attributed to particle agglomeration within the turbulent cyclone flow field.

The PACYC model was developed based on the Ho and Sommerfeld [15; 24] particle agglomeration model, superimposed on the Mothes and Löffler [8] particle collection model for isolated cyclones or on the Salcedo et al. [5] model for mechanical recirculation systems. Coupling these with electrostatic precipitator classical models [18–20] enables the predictions of these recirculation systems with an electric field.

On average, Hurricanes[®] can reduce emission of comparable pressure drop high efficiency cyclones by about 40-60%, mechanical ReCyclones[®] by about 75-80% and ReCyclones[®] EH by about 90-95%. Their effectiveness has already been shown at pilot and industrial scales, for a variety of very fine dusts.

5 Nomenclature

η	Global efficiency
$\eta_{cyclone}$	Cyclone efficiency
η_{conc}	Concentrator efficiency
η_{ER}	Electrical efficiency
η_{MR}	Mechanical efficiency
$\eta_{i,j}$	Grade-efficiency for diameter i and slice j
ρ	Fluid specific gravity ($\frac{kg}{m^3}$)
ρ_p	Particle specific gravity ($\frac{kg}{m^3}$)
C	Particle concentration ($\frac{kg}{m^3}$)
d_p	Particle diameter (m)
D_r	Turbulent dispersion coefficient ($\frac{m^2}{s}$)
$E(r)$	Electric field ($\frac{V}{m}$)
j_{SE}	Current density ($\frac{A}{m^2}$)
$P_{collision}$	Collision probability
Q^∞	Saturation particle charge (C)
Q	Particle charge (C)
Pe_p	Particle Peclet number
Re_p	Fluid Reynolds number
Sup	Virtual separation interface
t	Time (s)
u_r	Fluid radial velocity ($\frac{m}{s}$)
V	Applied voltage (V)
W	Electrical migration velocity ($\frac{m}{s}$)

References

- [1] R. L. Salcedo and M. A. Coelho. [Turbulent dispersion coefficients in cyclone flow: An empirical approach.](#) *Canadian Journal Of Chemical Engineering*, 77(4):609–617, August 1999.
- [2] R. L. Salcedo. High efficiency cyclones. European Patent 0972572, European Patent Bulletin, March 2000.
- [3] R. L. R. Salcedo and M. G. Candido. Global optimization of reverse-flow gas cyclones:

- application to small-scale cyclone design. *Separation Science and Technology*, 36(12):2707–2731, 2001.
- [4] R. L. Salcedo and M. J. Pinho. Pilot- and industrial-scale experimental investigation of numerically optimized cyclones. *Industrial & Engineering Chemical Research*, 42:145–154, 2003.
- [5] R. L. R. Salcedo, V. G. Chibante, A. M. Fonseca, and G. Candido. Fine particle capture in biomass boilers with recirculating gas cyclones: Theory and practice. *Powder Technology*, 172(2):89–98, 2007.
- [6] V. Chibante and R. and Salcedo. Comparing the performance of recirculating cyclones applied to the dry scrubbing of gaseous hcl with hydrated lime. *Industrial & Engineering Chemistry Research*, 48:1029–1035, 2009.
- [7] S. R. Wysk, L. A. Smolensky, and A. Murison. Novel particulate control device for industrial gas cleaning. *Filtration & Separation*, Jan/Fev:29–31, 1993.
- [8] H. Mothes and F. Löffler. Prediction of particle removal in cyclones separators. *International Chemical Engineering*, 28:231, 1988.
- [9] A. C. Hoffmann, A. Vansanten, R. W. K. Allen, and R. Clift. Effects of geometry and solid loading on the performance of gas cyclones. *Powder Technology*, 70:83–91, 1992.
- [10] Alex C. Hoffmann and A. Berrino. On the shape of grade efficiency curves computed for centrifugal dedusters by cfd with lagrangian particle tracking. *Advanced Technologies for Fluid-Particle Systems*, 95:13–17, 1999.
- [11] E. Hugi and L. Reh. Focus on solids strand formation improves separation performance of highly loaded circulating fluidized bed recycle cyclones. *Chemical Engineering Processing*, 39:263–273, 2000.
- [12] Alex C. Hoffmann and Louis E. Stein. *Gas Cyclones and Swirl Tubes - Principles, Design and Operation*. Springer, 2002.
- [13] C. H. Ho and M. Sommerfeld. Numerical calculation of dust separation in a gas cyclone paying due attention to particle agglomeration. *Chemie Ingenieur Technik*, 77(3):282–290, 2005.
- [14] H. Mothes and F. Löffler. About the influence of particle agglomeration on the separation in a gas cyclone. *Staub Reinhaltung Der Luft*, 44:9–14–, 1984.
- [15] M. Sommerfeld. Validation of a stochastic lagrangian modelling approach for inter-particle collisions in homogeneous isotropic turbulence. *International Journal Of Multiphase Flow*, 27(10):1829–1858, 2001.
- [16] D. Mao, J.R. Edwards, A.V. Kuznetsov, and R. Srivastava. A model for fine particle agglomeration in circulating fluidized bed absorbers. *Heat Mass Transference*, 38:379, 2002.
- [17] J. Paiva, R. Salcedo, and P. Araújo. Impact of particle agglomeration in cyclones. *Chemical Engineering Journal*, 162:861–876, 2010.
- [18] Harry J. White. *Industrial Electrostatical Precipitation*. International Society for Electrostatical Precipitation, 1963.
- [19] Sabert Oglesby. *Electrostatical Precipitation - Pollution Engineering and Technology 8*. Marcel Dekker Inc., 1978.
- [20] K. R. Parker. *Applied Electrostatic Precipitation*. Blackie Academic & Professional, 1997.
- [21] T. Lorenz. Heissgaseststaubung mit zyklonen. *VDI-Fortschrittsberichte, Dusseldorf*, 3:1–113, 1994.
- [22] R. Clift, M. Ghadiri, and Alex C. Hoffman. A critique of two models for cyclone performance. *AIChE Journal*, 37:285–289, 1991.
- [23] R. L. Salcedo. Collection efficiencies and particle-size distributions from sampling cyclones - comparison of recent theories with experimental-data. *Canadian Journal Of Chemical Engineering*, 71:20–27, 1993.
- [24] C. A. Ho and M. Sommerfeld. Modelling of micro-particle agglomeration in turbulent flows. *Chemical Engineering Science*, 57(15):3073–3084, 2002.
- [25] R. B Xiang and R. W. Lee. Numerical study of flow field in cyclones of different height. *Chemical Engineering and Processing*, 44:877–883, 2005.
- [26] H. F. Meier and M. Mori. Gas-solid flow in cyclones: The eulerian-eulerian approach. *Computers Chemical Engineering*, 22 sup:641–644, 1998.